

SURFACE CHARACTERISTICS OF ALUMINIUM FOIL

This catalogue was developed by the foil rollers organised in the European Aluminium Foil Association (EAFA) with the purpose to facilitate discussions between business partners. It describes the most common surface characteristics in more detail and is intended to provide common language for any potential discussion caused by potential visual surface characteristics on the aluminium foil.

With respect to any competition law this catalogue is not intended to substitute any individual agreements on quality and other topics between suppliers and customers.

June 2020



1 SCRATCHES

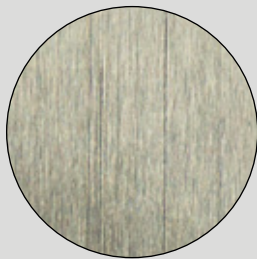

German: Kratzer
Italian: Graffi
Spanish: Rayas/Arañazos
French: Griffures

Mechanical damage to the aluminium surface in the form of sharp indentation. Can be periodically repeating with equidistant appearance or continuously or limited to certain area.

Possible root cause:

- Usually caused by a machine (rolling, rewinding, slitting)
- During handling
- Caused by movement during rewinding

Not to be confused with:

Wrinkles or friction marks

Mostly in machine direction but in isolated cases also in other directions:
Transverse scratch or „snowball“ (Scratch with material ejection, mainly in soft materials).



Transverse scratch („Snowball“)

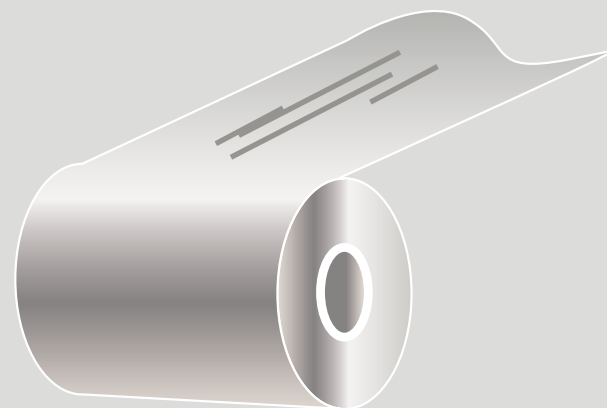

2

FRICTION MARKS



German: Reibkorrosion
(„Überziehkratzer“)

Italian: Segni da sfregamento

Spanish: Roces entre espiras /
Soldadura entre espiras

French: Friction

Randomly distributed mechanical damage in form of shallow modifications most likely to occur near the core.

Possible root cause:

- Layers moving during annealing, backwinding or separation with irregular tension. Micro sliding movements under load/pressure due to insufficient tension at recoiler.
- Created during annealing in case the material expands and recontracts afterwards.

Not to be confused with:

Scratches or oxidation

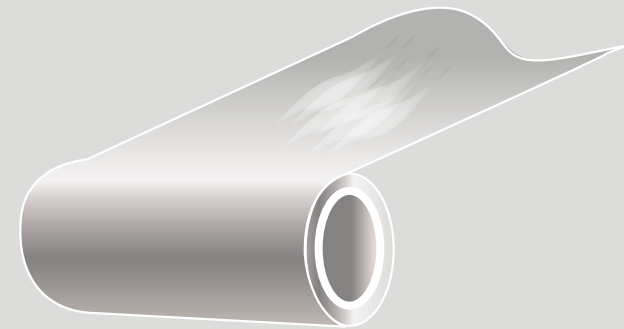
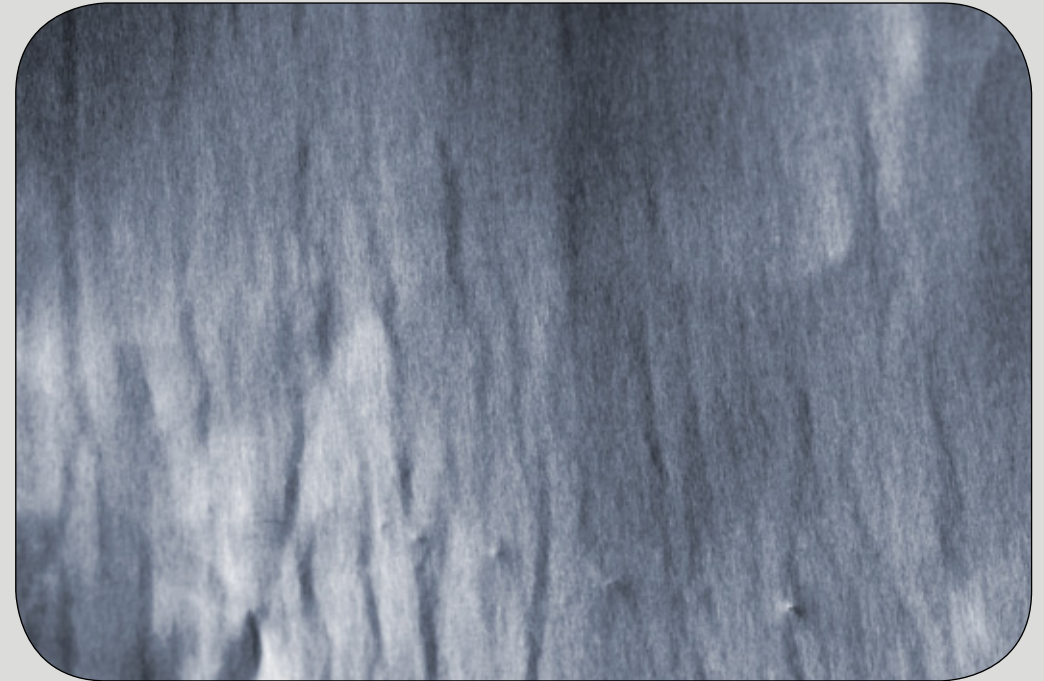

3 ROLL MARKS

German: Druckstellen
Italian: Segni cilindro
Spanish: Marcas de cilindro
French: Marques de cylindres

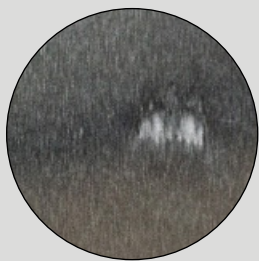

Damage to the foil surface resulting from damage on the rolling equipment, e.g. on the work roll. Equidistantly recurring, corresponding with contact between damaged equipment and aluminium surface.

Possible root cause:

- Locally damaged (work) rolls

Not to be confused with:

Scratches

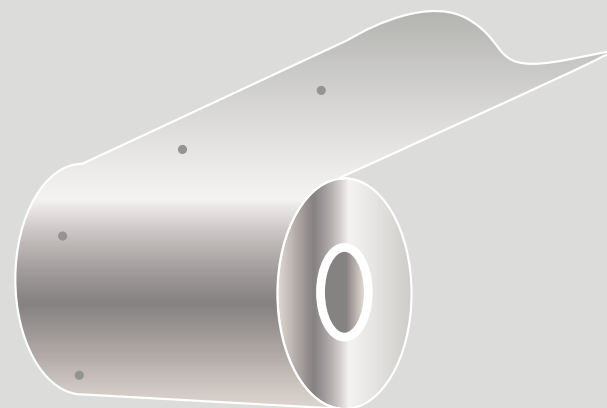

4 CHATTER MARKS

German: Rattermarken

Italian: effetto tapparella

Spanish: Vibraciones / Marcas de rectificado

French: Marques de rectification

Intermittent lines perpendicular to the rolling direction.

Possible root cause:

- Vertical vibrations of the rolling mill or work rolls
- Caused by vibration between the grinding wheel and the roll

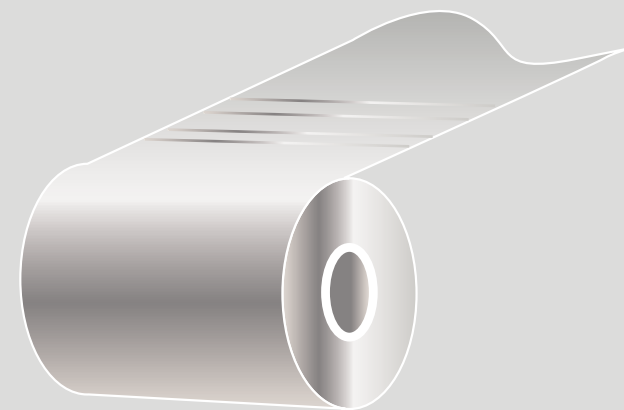

5 **STRIPES**

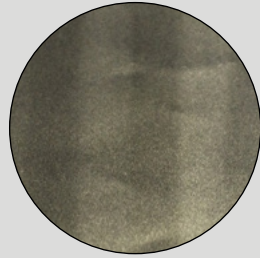

German: Streifen
Italian: Righe
Spanish: Bandas
French: Lignes

Purely visual, not causing thickness differences, can be present on one side or on both sides of the aluminium foil.

Possible root cause:

- Large variety of causes, some producing stripes all along the reel, some causing a local appearance.

Not to be confused with:

Scratches

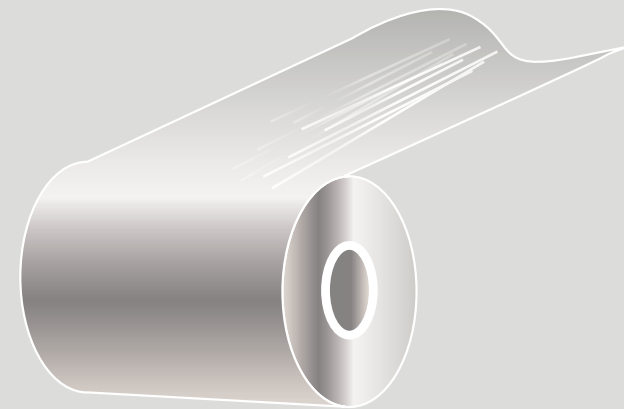

5.1 ROLLING STRIPES

German: Walzstreifen

Italian: Righe cilindro

Spanish: Bandas de laminación

French: Lignes de laminage

On gloss side only, constant in rolling direction.

Possible root cause:

- Local wear of work roll.
- Locally damaged work rolls originating from foreign material within the foil, caused by bad casting or upstream contaminations of the foil stock.



5.2 HEAT STRIPES

German: Hitzestreifen oder Schmarre

Italian: Righe da ciclo termico

Spanish: Bandas térmicas

French: Poches de chaleur

Straight to snaking grey stripes due to differences in temperature and/or flatness across the strip width.

Possible root cause:

- Temperature differences across the width of the material
- Locally thermally overstressed roller



6

GLOSS DIFFERENCE



German: Glanzunterschiede
Italian: Opaco fiammato
Spanish: Diferencia de brillo
French: Différence de brillance

The material appears in – usually two – different kinds of glosses on the matt side only. Gloss difference does not appear on gloss-side; usually in rolling direction, due to rolling the aspect ratio can be very long.

Possible root cause:

- Instability of separating oil application during doubling

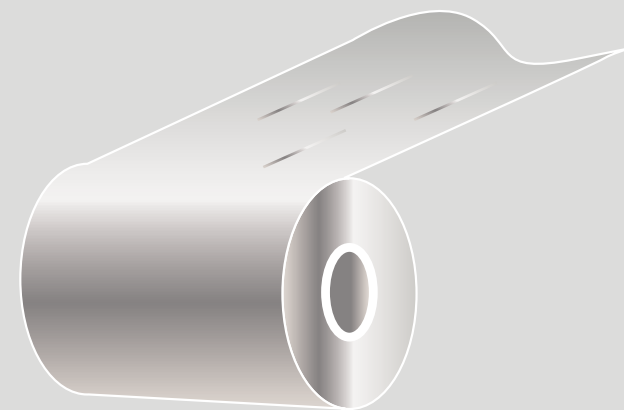
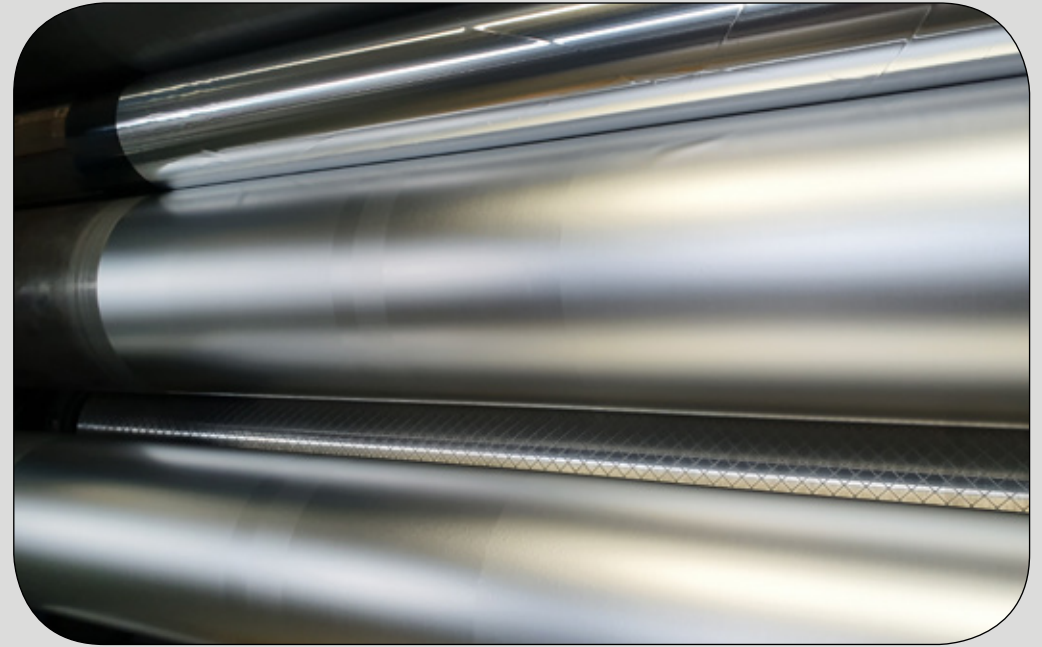

7

STAINS

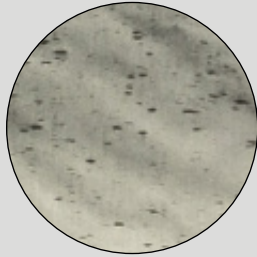

German: Flecken

Italian: Macchie estese

Spanish: Manchas

French: Tâches

Surface appears glossier in scattered areas, randomly distributed with light/dark contrast. Purely visual, not causing thickness differences.

During further rolling stains can become streaks.

Possible root cause:

- Contamination by foreign substances on the metal surface

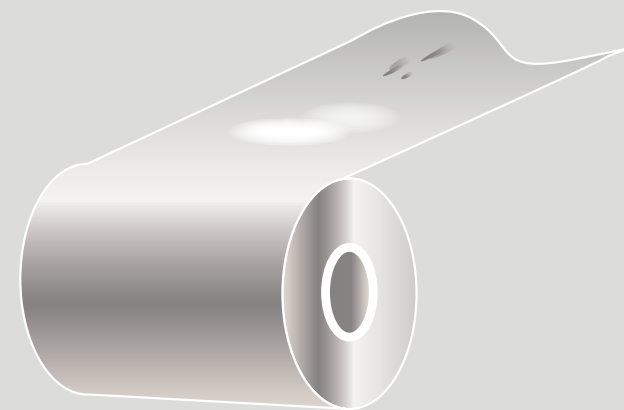

7.1 OIL STAINS

German: Ölflecken
Italian: Macchie da lubrificanti
Spanish: Machas de aceite/
Aceite quemado
French: Tâches d'huile



Brown stains usually on the edge of the foil.

Possible root cause:

- Incomplete evaporation and/or oxidation of lubricants

Not to be confused with:

Water stains, stripes or streaks



7.2 DIRT STAINS

German: Schmutzflecken
Italian: Macchie da gocciolamento
Spanish: Suciedad laminada
French: Tâches de saleté

Stains randomly distributed on the surface of the aluminium foil.

Possible root cause:

- Contamination with extraneous material

Not to be confused with:

Spots

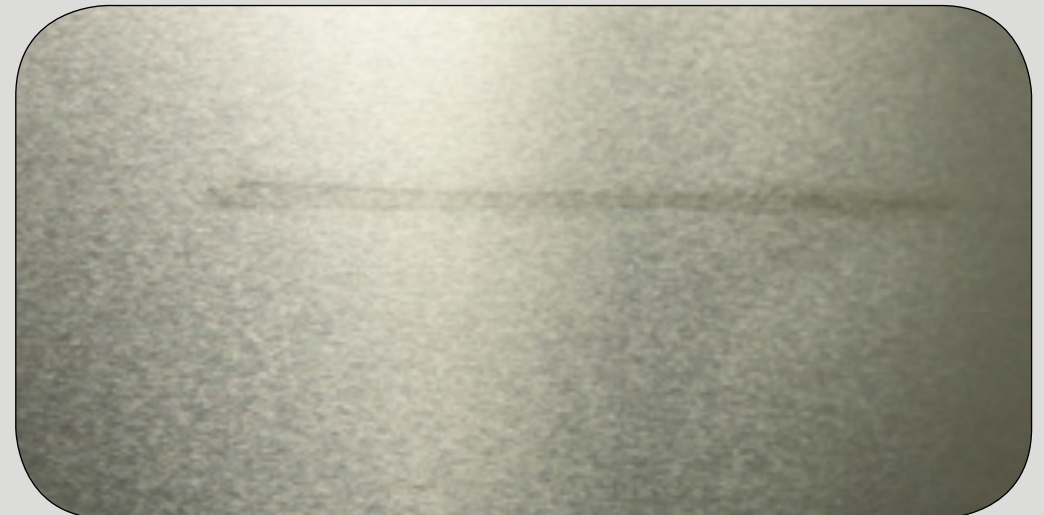

7.3 WATER STAINS

German: Wasserflecken

Italian: Ossidazione

Spanish: Oxidaciones/Manchas de agua

French: Oxydation

White stains, randomly distributed on the aluminium foil, depending in touch with water.

Possible root cause:

- Water dropping on the foil surface or condensation during storage and/or transport

Not to be confused with:

Oil stains or spots



8 STREAKS

German: Striche

Italian: Segni

Spanish: Direccionalidad/Bandeado/Vetas

French: Trainées grises

Mostly dark areas on the foil with elongated – stretched-appearance (high length/width-ratio).

Possible root cause:

- Local contamination on the web by foreign substance that has been rolled into the foil and elongated accordingly. (Original state of streaks is typically spots)

Not to be confused with:

Stripes or spots

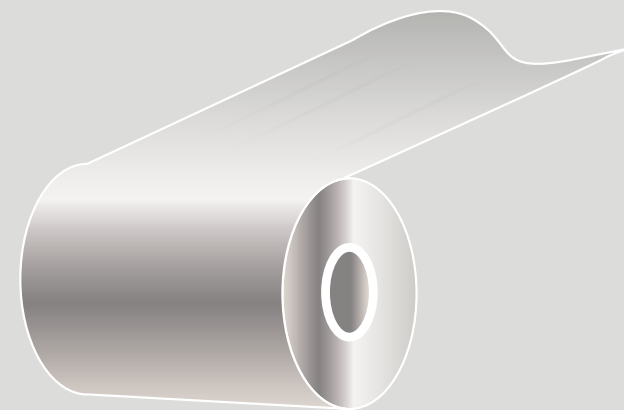

9 SPOTS

German: Tropfen

Italian: Macchie

Spanish: Manchas puntuales

French: Défauts en point

Drop or “comet”-like appearance, randomly distributed, contrasting appearance with rolled surface. During further rolling spots can become streaks.

Possible root cause:

- Liquid (water or oil) or debris dropping on material

Not to be confused with:

Stains

9.1. BLACK SPOTS

German: Abriebsflecken oder Schwarze Flecken

Italian: Macchie Nere

Spanish: Manchas negras

French: Points noirs

Black spots randomly distributed on the surface of the aluminium foil.

Possible root cause:

- Small particles of aluminium and aluminium oxide generated by abrasion in the machine and subsequently transferred to the surface.

Not to be confused with:

Stains

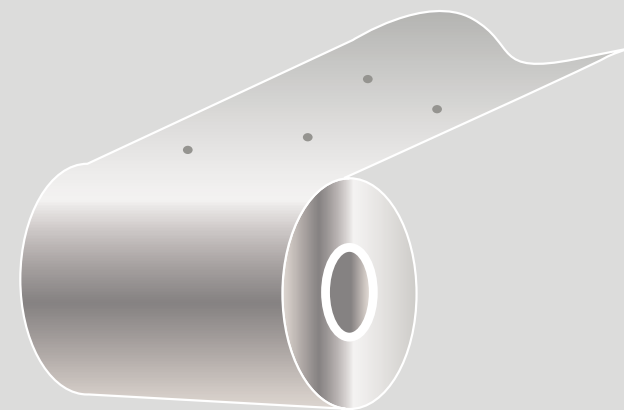
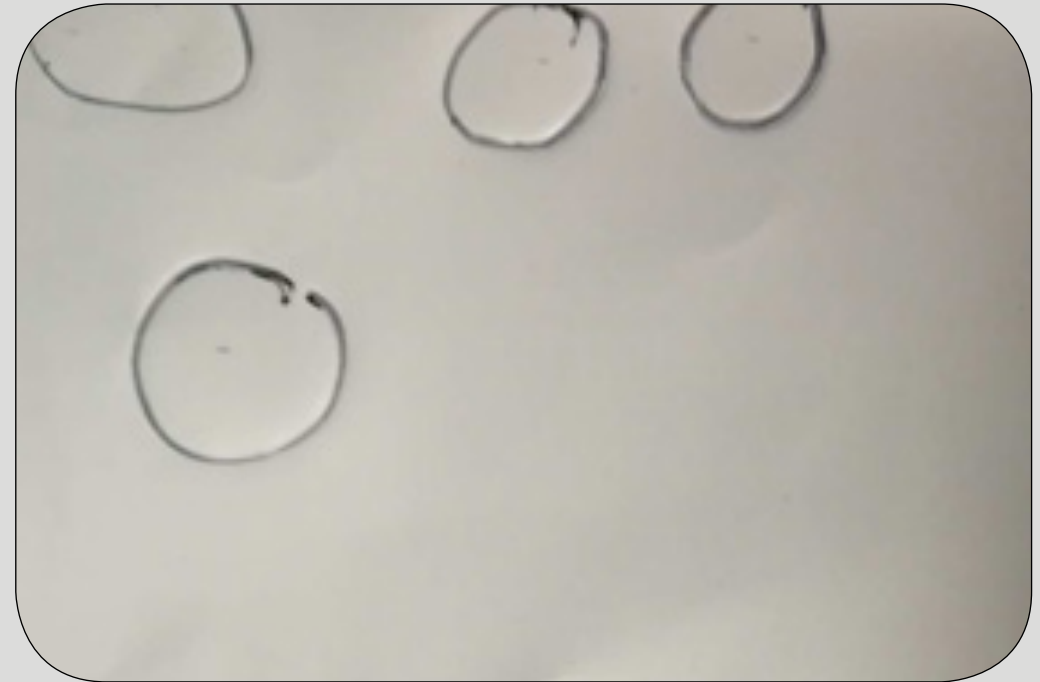

10

BROKEN MATTS



German: Glanzstellen oder Blitzer

Italian: Opaco puntinato

Spanish: Puntos brillantes

French: Points brillants

Bright spots on matt side of mechanical origin, only visible in double foil at last pass, of mechanical origin.

Possible root cause:

- Too much deformation strength applied
- Too high rolling speed

Not to be confused with:

Spots

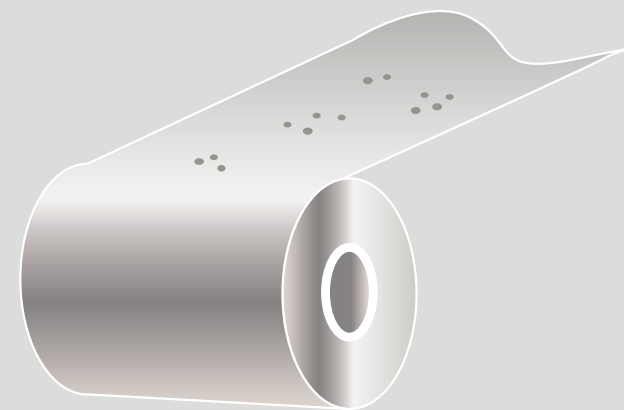
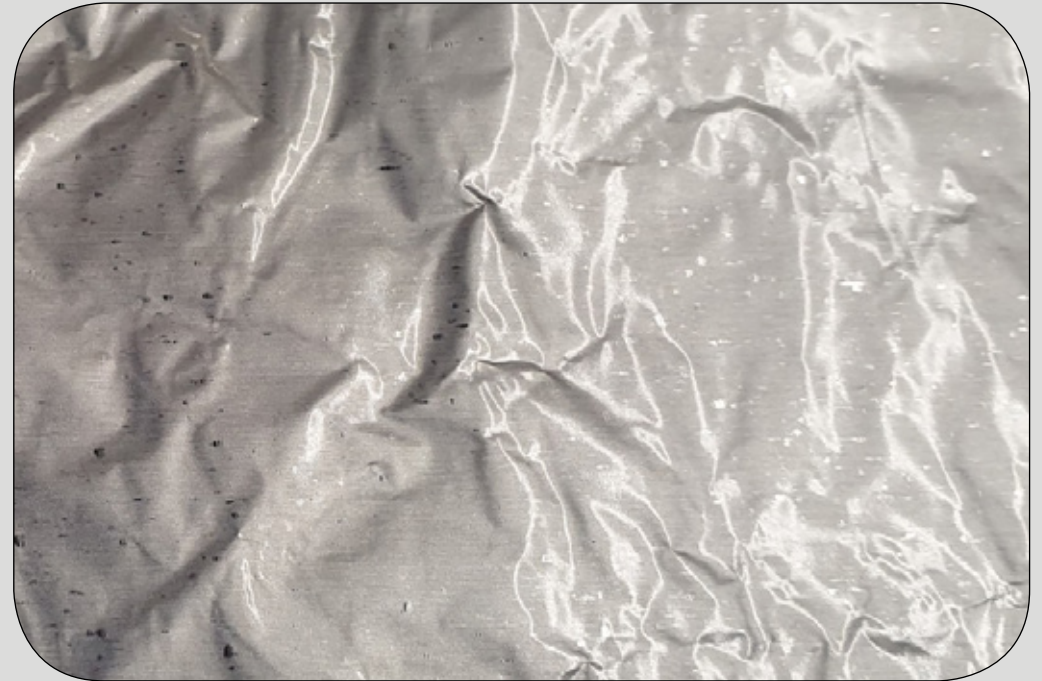

11

GROOVES

German: Rillen

Italian: Grooves (oblique)/
cordonature (rolling direction)

Spanish: Pliegues

French: Fronces

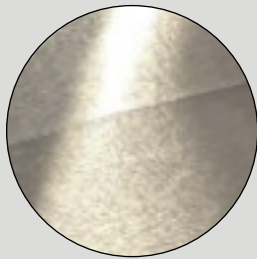

Sharp deviation from flatness, (haptically) noticeable structuring of in the material, deformation of material in rolling direction, usually without a change in position and intensity.

Possible root cause:

- Unfavourable flatness profiles
- Deviating roll line
- Material movement during the annealing process
- Unfavourable slitte setting

Not to be confused with:

wrinkles, stripes or streaks

Grooves can result in different patterns on the finished foil reel, esp. <10mic – example “Seilfalten” (commonly visible on reel only)

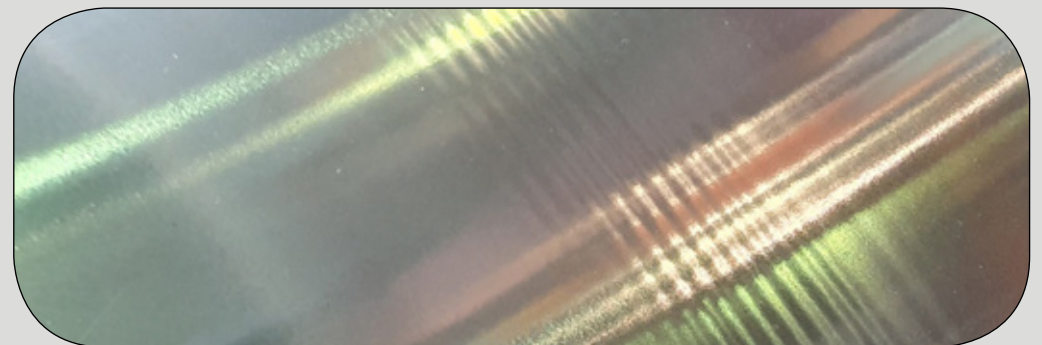
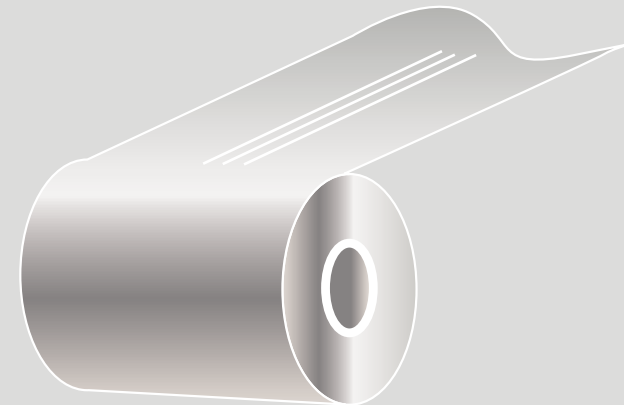
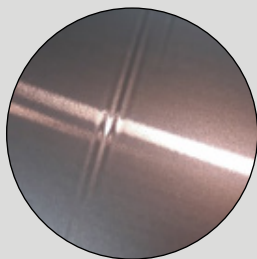

12 **WRINKLES**

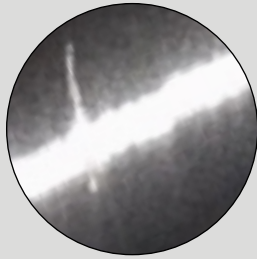

German: Falten
Italian: Pieghe
Spanish: Arrugas
French: Plis

Material appears overlapped at certain (local) areas.

Possible root cause:

- Flatness issues
- Wrong machine parameters
- Wrong aligned deflection rollers

Not to be confused with:

Grooves

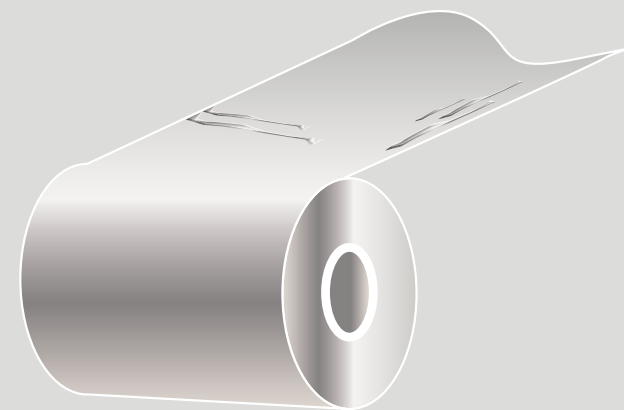

The European Aluminium Foil Association (EAFA) is the main trade association, specifically representing companies engaged in the rolling and rewinding of aluminium foil and the manufacturing of semi-rigid alufoil containers and household foil in Europe. With its more than 40 members, the organisation represents the total aluminium foil rolling market in Europe.



Mörsenbroicher Weg 200
40470 Düsseldorf, Germany
www.alufoil.org